

# TriOxmatic® 690

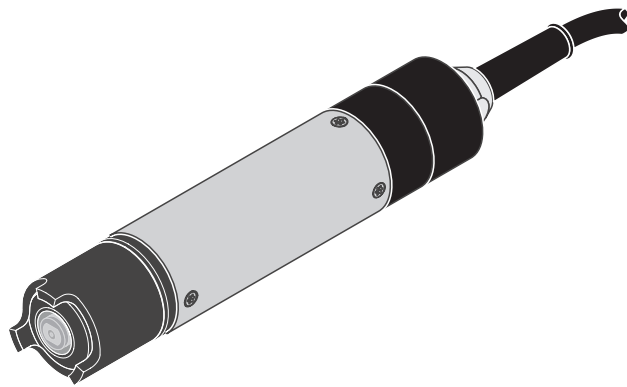

## Dissolved Oxygen Sensor

**Accuracy when going to  
press**

The use of advanced technology and the high quality standard of our instruments are the result of continuous development. This may result in differences between this operating manual and your instrument. Also, we cannot guarantee that there are absolutely no errors in this manual. Therefore, we are sure you will understand that we cannot accept any legal claims resulting from the data, figures or descriptions.

**Note**

The latest version of the present operating manual can be found on the Internet under [www.WTW.com](http://www.WTW.com).

**Copyright**

© Weilheim 2006, WTW GmbH  
Reprinting - even as excerpts - is only allowed with the explicit written authorization of WTW GmbH, Weilheim.  
Printed in Germany.

## TriOxmatic® 690 - Contents

<b>1</b>	<b>Overview</b>	<b>47</b>
1.1	Structure of the TriOxmatic® 690	47
1.2	Recommended fields of application	47
<b>2</b>	<b>Safety</b>	<b>49</b>
2.1	General information on safety	49
2.2	Authorized use	49
2.3	General safety instructions	50
<b>3</b>	<b>Commissioning</b>	<b>51</b>
3.1	Scope of delivery	51
3.2	Installation	51
3.3	Commissioning / Getting the instrument ready for measuring	52
<b>4</b>	<b>Measuring / Operation</b>	<b>53</b>
4.1	Measuring	53
4.2	Calibration	54
4.2.1	General information on calibration	54
4.2.2	Calibration in water vapor-saturated air	55
4.3	Function check	56
<b>5</b>	<b>Maintenance, cleaning, disposal, and replacement</b>	<b>59</b>
5.1	General maintenance instructions	59
5.2	Cleaning the sensor shaft and membrane	59
5.3	Changing the electrolyte and membrane cap	62
5.4	Cleaning the electrodes	67
5.4.1	Cleaning the gold working electrode	69
5.4.2	Cleaning the silver counter electrode	70
5.5	Checking the sensor for freedom from zero-current	76
5.6	Storage	77
5.7	Disposal	77
5.8	Maintenance equipment and replacement parts	78
<b>6</b>	<b>What to do if...</b>	<b>79</b>

<b>7</b>	<b>Technical data</b>	<b>81</b>
7.1	General data	81
7.2	Measurement conditions	83
7.3	Characteristic data on delivery	84
7.4	Electrical data	84

# 1 Overview

## 1.1 Structure of the TriOxmatic® 690

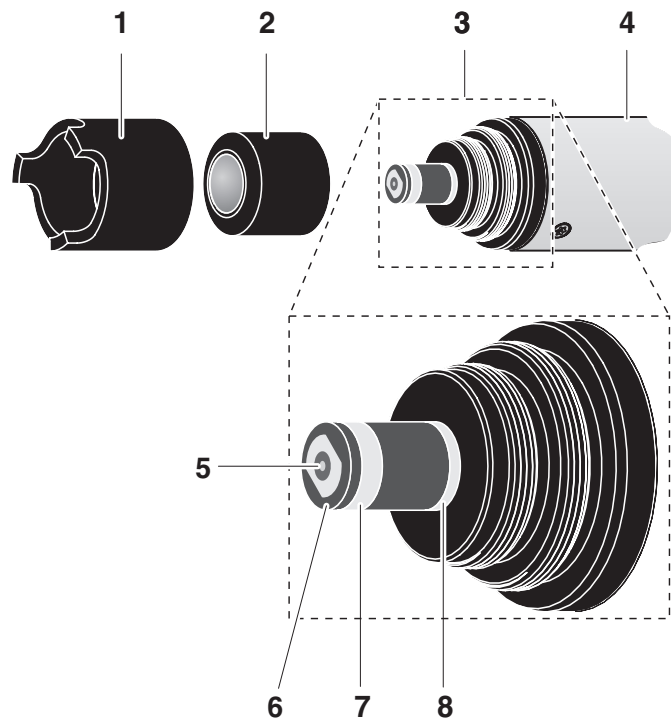

Fig. 1-1 Structure of the D. O. sensor

1	Protective hood
2	WP 600 membrane cap
3	Electrode unit
4	Shaft

*Electrode unit:*

5	Gold working electrode (cathode)
6	Insulator
7	Silver counter electrode (anode)
8	Reference electrode

## 1.2 Recommended fields of application

Stationary measurements in water/wastewater applications.



## 2 Safety

### 2.1 General information on safety

These safety instructions contain all instructions that have to be followed for a safe operation of the TriOxmatic® 690 D. O. sensor. Before starting any work with the TriOxmatic® 690, carefully read the safety instructions and strictly follow all protective measures mentioned.

Always store and make available these safety instructions together with the operating manual in the vicinity of the place of installation as possible.

#### General safety instructions

Safety instructions in this operating manual can be recognized by the warning symbol (triangle) in the left column. The signal word (e. g. "Caution") indicates the level of the danger:



#### Warning

indicates instructions that must be followed precisely in order to prevent serious dangers to persons.



#### Caution

indicates instructions that must be followed precisely in order to avoid slight injuries or damage to the instrument or the environment.

#### Other labels



#### Note

indicates notes that draw your attention to special features.



#### Note

indicates cross-references to other documents, e.g. operating manuals.

### 2.2 Authorized use

The authorized use of the TriOxmatic® 690 is stationary D. O. measurement.

The technical specifications according to chapter 7 TECHNICAL DATA must be observed. Only operation according to the instructions given in this operating manual is considered to be authorized.

Any other use is considered to be **unauthorized**. Unauthorized use invalidates any claims with regard to the guarantee.

## 2.3 General safety instructions

### Function and operational safety

The sensor left the factory in a safe and secure technical condition.

The failure-free function and operational safety of the sensor is only guaranteed if the generally applicable safety measures and the special safety instructions in this operating manual are followed during its use.

The failure-free function and operational safety of the sensor is only guaranteed under the environmental conditions that are specified in chapter 7 TECHNICAL DATA.

The specified temperature (chapter 7 TECHNICAL DATA) must be maintained during the operation and transport of the sensor. Protect the sensor, particularly against frost or overheating.

### Safe operation

If safe operation is no longer possible, the sensor must be taken out of operation and secured against inadvertent operation.

Safe operation is no longer possible if the sensor:

- has been damaged in transport
- has been stored under adverse conditions for a lengthy period of time
- is visibly damaged
- no longer operates as described in this manual.

If you are in any doubt, contact the supplier of your sensor.

### Obligations of the operator

The operator of the sensor must ensure that the following rules and regulations are followed when dealing with hazardous substances:

- EEC directives for protective labor legislation
- National protective labor legislation
- Safety regulations
- Safety data sheets of the chemical manufacturer.



## 3 Commissioning

### 3.1 Scope of delivery

- TriOxmatic® 690  
The sensor is filled with electrolyte and provided with a protective hood and protective caps.
- ZBK 600 accessory kit
- Operating manual.

### 3.2 Installation

#### Connection to the measuring transmitter

The TriOxmatic® 690 connection cable has a screw plug to be connected to the Oxi input socket of a measuring transmitter. It is connected to the terminal strip of measuring transmitters without an Oxi input socket via the ADA/AMPH adapter.

For detailed information please refer to the operating manual of the measuring transmitter.



#### Note

Do not suspend the sensor on the sensor connection cable. Use a sensor holder or armature. Information on this and other TriOxmatic® 690 accessories is given in the WTW catalog and on the Internet.

### 3.3 Commissioning / Getting the instrument ready for measuring

- |   |  |
|---|--|
| 1 | Pull the protective cap off the protective hood of the sensor.                                     |
| 2 | Leave the sensor to lie in the air for at least 60 minutes while it is switched on (polarization). |

**Note**

For the sensor to polarize, the following conditions must be fulfilled:

- The sensor is connected with the measuring transmitter.
- The measuring transmitter is in operation

- |   |   |
|---|---|
| 3 | Calibrate the sensor (see operating manual of the measuring transmitter). |
|---|---|

**Precision measurements**

Recommendation: In order to carry out precision measurements, leave the sensor to polarize for a longer period of time, e.g. overnight, and recalibrate it the following day.

## 4 Measuring / Operation

### 4.1 Measuring



#### Warning

**Contact with the sample can lead to danger to the user!  
Depending on the type of sample, suitable protective measures must be taken (protective clothing, protective goggles, etc.).**

For measuring submerge the operable sensor in the test sample. The measured value is available immediately on submersing.



#### Note

Do not suspend the sensor on the sensor connection cable. Use a sensor holder or armature. Information on this and other TriOxmatic® 690 accessories is given in the WTW catalog and on the Internet.

#### Minimum approach flow

The minimum required approach flow at the sensor must be present during measurement (see chapter 7 TECHNICAL DATA). The minimum approach flow can, e.g. be present due to:

- natural movement of the water (flow rate, sea disturbance)
- turbulences in the activated sludge basin.

## 4.2 Calibration

### 4.2.1 General information on calibration

**Why calibrate?**

During the operation of a D.O. sensor, the slope of the D.O. sensor changes with time. The calibration procedure determines the current slope of the sensor.

**When to calibrate?**

Calibrate before measuring and at regular intervals (depending on the application).

**Calibration procedure,**

Ideally, calibration takes place in water vapor-saturated air. To do so, position the sensor approx. 2 cm above a water surface, for example in a narrow bucket or similar container with water.

In the case of air temperatures under 5 °C we recommend to calibrate not in air but in air-saturated water that has a higher temperature. You obtain air-saturated water by pouring water several times in and out of two vessels so that it sparkles.

**Note**

For calibration the membrane always has to be clean, for calibration in air it has to be dry. Clean contaminated sensors before calibration (see section 5.2 CLEANING THE SENSOR SHAFT AND MEMBRANE).

#### 4.2.2 Calibration in water vapor-saturated air

- 1 If necessary, clean the sensor and membrane and dry the membrane (see section 5.2 CLEANING THE SENSOR SHAFT AND MEMBRANE).

##### Calibrating position

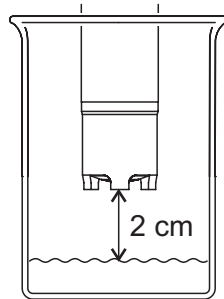

- 2 Bring the sensor into the calibrating position. To do so, position the sensor approx. 2 cm above a water surface, best in a narrow bucket or similar container with water. When doing so, no liquid should be brought on the membrane.
- 3 Start calibration as described in the operating manual of the measuring transmitter.



##### Note

In the case of air temperatures under 5 °C do not calibrate the sensor in air but in air-saturated water that has a higher temperature. You obtain air-saturated water by pouring water several times in and out of two vessels so that it sparkles.

Then immerse the sensor in a vessel with air-saturated water (calibrating position) and calibrate as described above.

### 4.3 Function check

The function check is the simplest way of letting you know whether the sensor needs to be cleaned and calibrated.



**Note**

The function check can either be performed in water vapor-saturated air or in air-saturated water.

In the case of air temperatures under 5 °C we recommend to perform the function check not in air but in air-saturated water that has a higher temperature.



**Note**

The function check is carried out in the measuring mode, % saturation.

#### Function check in water vapor-saturated air

Proceed as follows:

- |   |   |
|---|---|
| 1 | Take the sensor out of the measuring solution and position it approx. 2 cm above a water surface, best in a narrow bucket or similar container with water. When doing so, no drops of liquid should be on the membrane. |
|---|---|

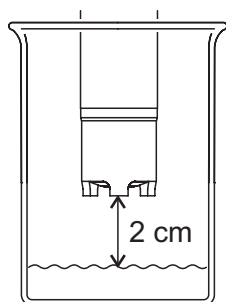

- |   |   |
|---|---|
| 2 | Wait at least 15 minutes for the temperature to adapt.  |
| 3 | On the measuring transmitter, select <i>Saturation</i> (unit %) and switch to the measured value display. |
| 4 | Read the measured value and determine whether it lies within the range of precision required by the user. |



**Note**

If there are large temperature differences between the sample and the air above the surface of the water, a balancing period of more than 15 minutes may be required.

**Measured values within the required precision**

If the measured value lies within the range of precision required by the user, no cleaning or recalibrating is necessary.

Example:

Required precision      5 %

Measured value in air:    97 % saturation (nominal value: 100%)

⇒ No cleaning or recalibration is necessary as the measurement error lies within the range of precision required by the user.

**Measured values outside the required precision**

If the measured value lies outside the range of precision required by the user, clean the sensor shaft and membrane (see section 5.2) and calibrate the sensor (see section 4.2).

**Note**

In the case of air temperatures under 5 °C do not perform the function check in air but in air-saturated water that has a higher temperature. You obtain air-saturated water by pouring water several times in and out of two vessels so that it sparkles.

Then submerge the sensor in a vessel with air-saturated water and perform the function check as described above.





## 5 Maintenance, cleaning, disposal, and replacement

### 5.1 General maintenance instructions



#### Warning

Contact with the sample can lead to danger to the user!  
Depending on the type of sample, suitable protective measures must be taken (protective clothing, protective goggles, etc.).

### 5.2 Cleaning the sensor shaft and membrane

For normal operation (e.g. municipal wastewater), cleaning and calibration are strongly recommended:

- in the case of pollution (according to visual check)
- in the case of suspected incorrect measured values (usually too low)
- if the measured value lies outside the range of precision required by the user during the function check.

#### Cleaning agents

Contamination	Cleaning agents
Sludge and loosely adhering dirt, biological deposits	Soft cloth or soft sponge, warm tapwater with detergent
Salt and / or lime deposits	Acetic acid (volume percentage = 20 %), soft cloth or soft sponge

**Cleaning**

- |   |  |
|---|--|
| 1 | Pull the sensor out of the sample.   |
| 2 | Get rid of any coarse contamination on the sensor (e.g. brush it off in a bucket of tapwater, wash it down with a hose or wash it off with a cloth). |
| 3 | Unscrew the protective hood from the sensor.   |

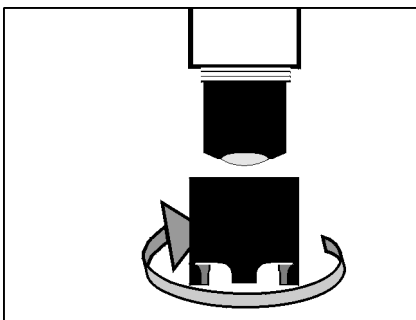

**Caution**

Acetic acid irritates the eyes and the skin. When handling acetic acid, always wear protective gloves and protective goggles.

- |   |   |
|---|---|
| 4 | <b>Carefully</b> clean the sensor shaft and membrane as specified in the CLEANING AGENTS section. |
|---|---|



**Caution**

Clean the membrane very carefully!  
 Make sure the membrane is not damaged, e.g. by sharp-edged objects, by laying it on sharp stones, etc.

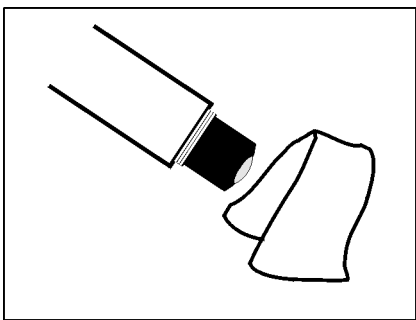

- |   |   |
|---|---|
| 5 | Then, rinse it thoroughly with tap water. |
| 6 | Also clean and rinse the protective hood. |

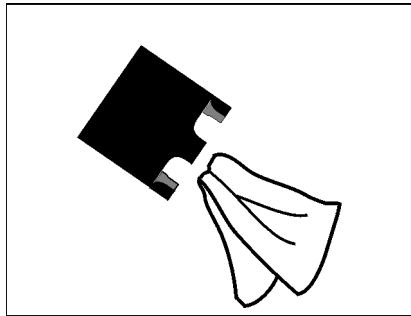

7 | Screw the protective hood back on again.

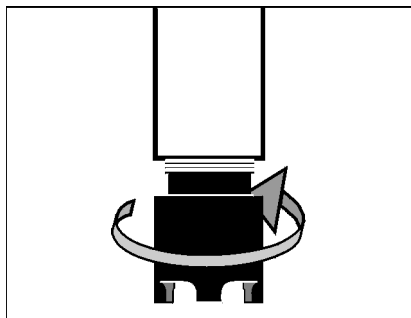

8 | If necessary, carefully dry the membrane with a lint-free paper towel.

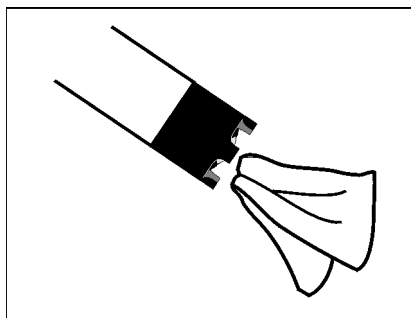

9 | Calibrate the sensor (see section 4.2 CALIBRATION).

### 5.3 Changing the electrolyte and membrane cap

WTW delivers the sensor ready for operation. The electrolyte solution and membrane cap must only be replaced if:

- a calibration error occurs due to a highly contaminated membrane
- the membrane is damaged (SensLeck or SensReg message)
- the electrolyte solution is depleted or the counter electrode is poisoned (SensReg message)
- after the gold working electrode and silver counter electrode have been cleaned



#### Caution

**Before unscrewing the membrane cap, disconnect the sensor from the instrument. Otherwise, undesirable electrochemical reactions can occur that may lead to the destruction of the sensor.**



#### Note

Unscrew the membrane cap for maintenance purposes only. After doing so, always use a new membrane cap!

#### Changing the electrolyte and membrane cap

1	Pull the sensor out of the sample.
2	Get rid of any coarse contamination on the sensor (e.g. brush it off in a bucket of tap water, wash it down with a hose or wash it off with a cloth).
3	Disconnect the sensor from the instrument.

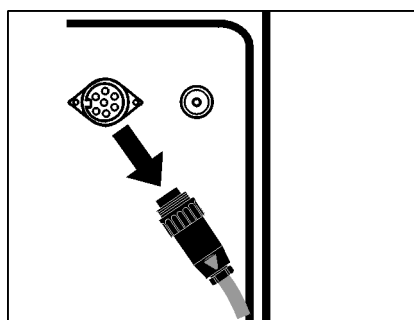

4	Unscrew the protective hood from the sensor.
---	--

**Caution**

The ELY/A electrolyte solution irritates eyes, skin and mucus membranes. If it comes into contact with the eyes, rinse thoroughly with water and consult a doctor! During working activities, always wear suitable protective gloves and protective goggles/face shield! Follow the safety datasheet.

- 5 | Unscrew the membrane cap (for disposal of membrane cap and electrolyte solution, see section 5.7).

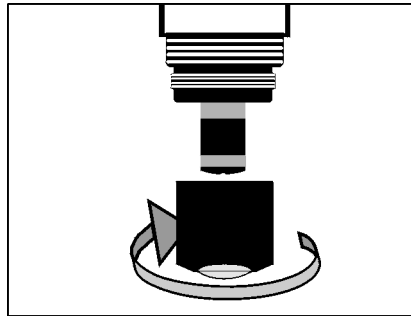

- 6 | Rinse the sensor head with tap water.

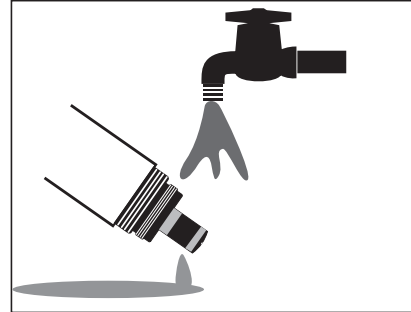

- 7 | Carefully rub the silver counter electrode with a paper towel and rinse it with deionized water.

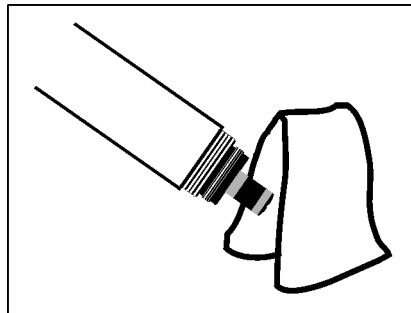

- 8 Thoroughly rinse the sensor head with electrolyte solution.

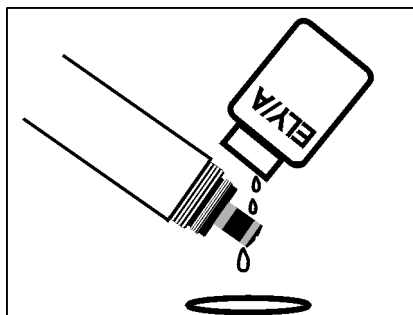

- 9 Fill a new WP 600 membrane cap with ELY/A electrolyte solution (see section 5.8 MAINTENANCE EQUIPMENT AND REPLACEMENT PARTS).

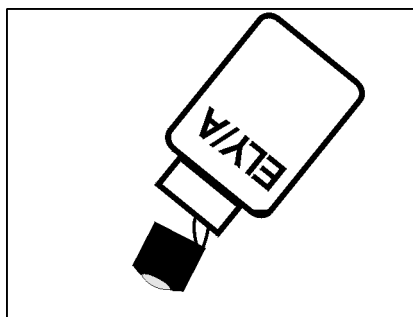

- 10 Throw away the first filling and fill the membrane cap with electrolyte solution once more.

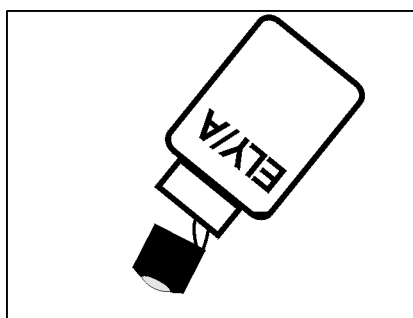

- |    |   |
|----|---|
| 11 | Remove any air bubbles by carefully tapping the membrane cap. |
|----|---|

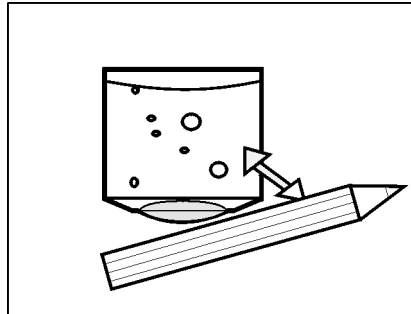

### Caution

The ELY/A electrolyte solution irritates eyes, skin and mucus membranes. If it comes into contact with the eyes, rinse thoroughly with water and consult a doctor! During working activities, always wear suitable protective gloves and protective goggles/face shield! Follow the safety datasheet.

- |    |  |
|----|--|
| 12 | Screw the membrane cap onto the shaft while holding the sensor at an angle. Excess electrolyte solution is forced out of the ventilation area. |
|----|--|

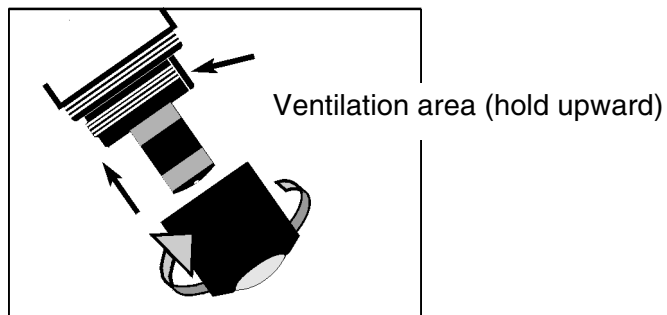

- |    |   |
|----|---|
| 13 | The filling should be free of air bubbles as far as possible. However, small air bubbles do not cause any interference. |
|----|---|



- |    |  |
|----|--|
| 14 | After approx. 60 minutes polarization time, the sensor is ready for operation. |
|----|--|

- |    |                         |
|----|-------------------------|
| 15 | Recalibrate the sensor. |
|----|-------------------------|

**Precision measurements**

Recommendation: In order to carry out precision measurements, leave the sensor to polarize for a longer period of time, e.g. overnight, and recalibrate it the following day.

**Note**

In the following cases, you must refill the sensor once more:

- If there are large air bubbles
- If there are air bubbles on the gold working electrode
- For measurements at high water pressure, even if small air bubbles are present. Otherwise, the membrane and, as a result, the measuring characteristics could change.
- If the sensor cannot be calibrated.



## 5.4 Cleaning the electrodes

The counter electrode and reference electrode always show a coloration. This is necessary for the operation of the sensor. This is not contamination. Cleaning is only required in cases of slopes that are too small or too large (the sensor cannot then be calibrated) that cannot be resolved by changing the membrane cap and electrolyte solution.



### Caution

**Before unscrewing the membrane cap, disconnect the sensor from the instrument. Otherwise, undesirable electrochemical reactions can occur that may lead to the destruction of the sensor.**

### Preparatory activities

1	Pull the sensor out of the sample.
2	Get rid of any coarse contamination on the sensor (e.g. brush it off in a bucket of tap water, wash it down with a hose or wash it off with a cloth).
3	Disconnect the sensor from the instrument.

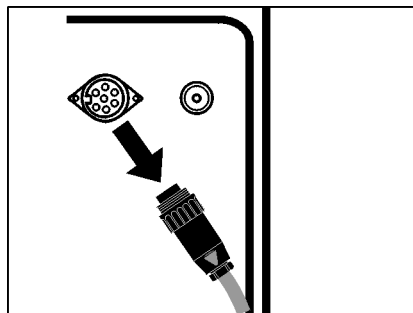

4	Unscrew the protective hood from the sensor.
---	--



### Caution

**The ELY/A electrolyte solution irritates eyes, skin and mucus membranes. If it comes into contact with the eyes, rinse thoroughly with water and consult a doctor! During working activities, always wear suitable protective gloves and protective goggles/face shield! Follow the safety datasheet.**

5	Unscrew the membrane cap (for disposal of membrane cap and electrolyte solution, see section 5.7).
---	--

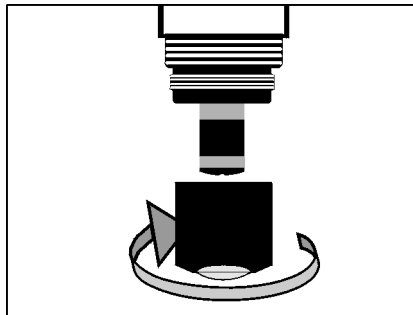

6 | Rinse the sensor head with tap water.

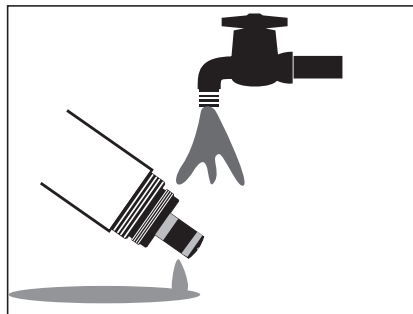

### 5.4.1 Cleaning the gold working electrode

- 1 | Moisten the gold working electrode and the SF 300 polishing strip (see section 5.8 MAINTENANCE EQUIPMENT AND REPLACEMENT PARTS) with deionized water.
- 2 | Using the rough side of the **wet** SF 300 polishing strip, polish off any contamination from the gold working electrode using light pressure.



#### Caution

Do not use any conventional sandpaper or glass-fiber brushes. They could damage the electrode.

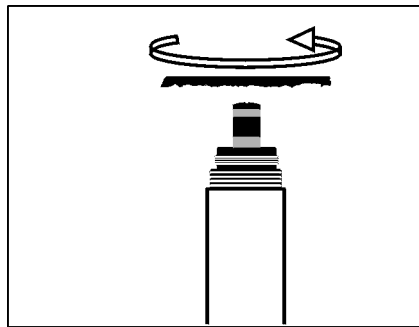

- 3 | Rinse the sensor head with deionized water.

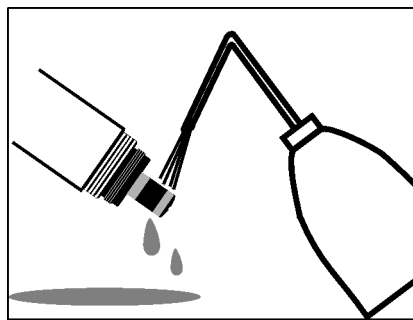

#### Note

Cleaning the gold working electrode may already be sufficient to enable the sensor to be calibrated again. For safety, however, we recommend to also clean the silver counter electrode (see section 5.4.2) and to use a new membrane cap afterwards.

### 5.4.2 Cleaning the silver counter electrode

We recommend to clean the silver counter electrode with the RA 600 cleaning attachment that is available as an accessory (see section 5.8 MAINTENANCE EQUIPMENT AND REPLACEMENT PARTS). This prevents the reference electrode from coming into contact with the cleaning solution. However, it is also possible to clean the silver counter electrode in a beaker.



#### Caution

The reference electrode must not come into contact with the cleaning solution under any circumstances. This could destroy the reference electrode and cause the sensor to become defective. However, no danger can arise if the RA 600 is used correctly.

#### Variant 1: Cleaning the silver counter electrode with the RA 600 cleaning attachment

- 1 Wipe the silver counter electrode with a lint free paper towel and carefully remove any loose deposits.

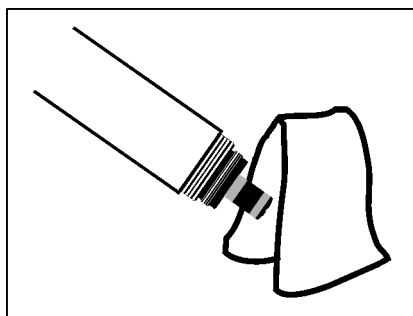

- 2 Screw the cleaning attachment onto the sensor, instead of the membrane cap.

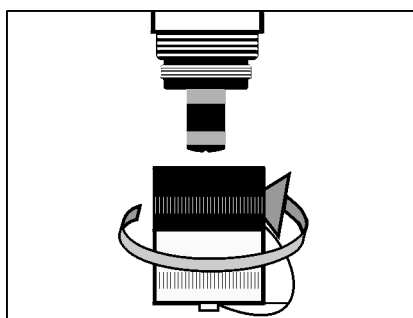

#### Caution

Never lubricate with oil or grease the inner O-ring in the RA 600 cleaning attachment!

- 3 Remove the screw cap from the safety cap of the cleaning attachment.

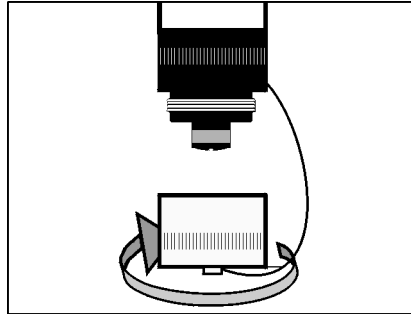

- 4 Fill the screw cap with RL-AG/Oxi cleaning solution (see section 5.8 MAINTENANCE EQUIPMENT AND REPLACEMENT PARTS).

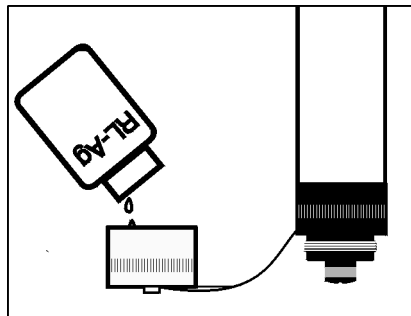

- 5 Screw the sensor with the safety cap onto the screw cap.

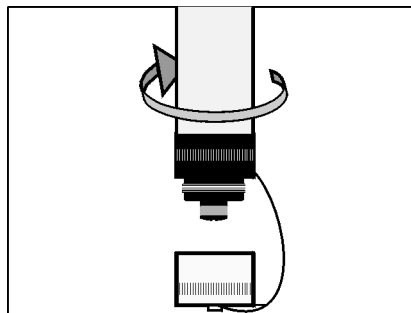

- 6 Leave the cleaning solution for a maximum of 1 hour to take effect.

7 Unscrew the screw cap.

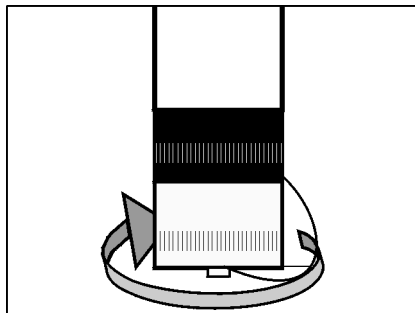

8 Thoroughly rinse the electrode unit with the safety cap on with deionized water.

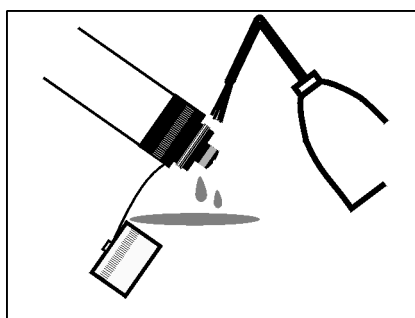

9 Unscrew the safety cap.

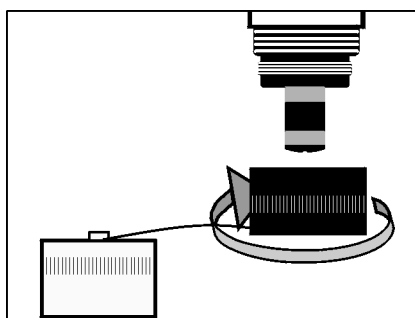

10 Rinse the sensor head and electrode unit several times with deionized water.

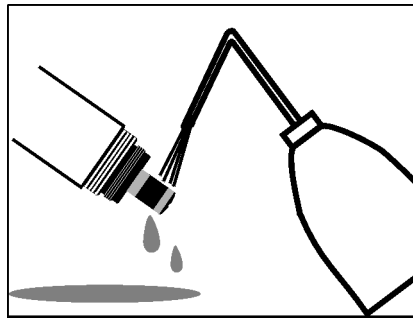

- 11 | Water the sensor head and electrode unit in deionized water for at least an hour.

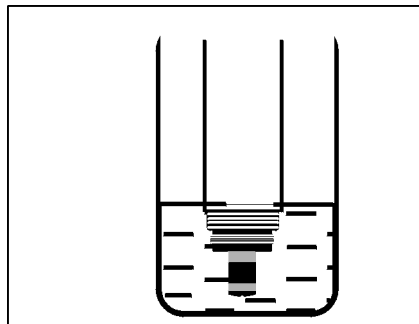

- 12 | Carefully shake off the drops of water.

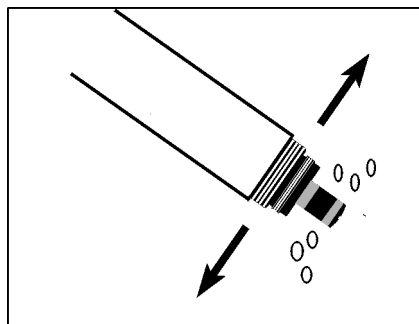

- 13 | Fill a new WP 600 membrane cap and screw it on (see section 5.3 CHANGING THE ELECTROLYTE AND MEMBRANE CAP).

- 14 | Connect the sensor to the measuring transmitter again.

- 15 | After approx. 60 minutes, the sensor is ready for operation.

- 16 | Recalibrate the sensor.



**Variant 2:**  
**Cleaning the silver  
counter electrode in a  
beaker**

- 1 Wipe the silver counter electrode with a lint free paper towel and carefully remove any loose deposits.

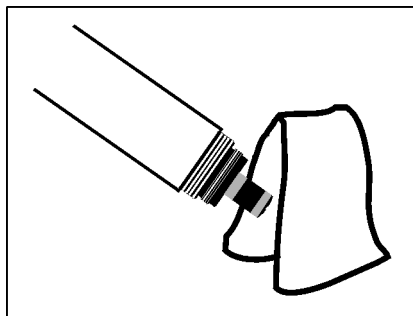

- 2 Fill a beaker (150 ml, high-sided form) with approx. 25 ml RL-AG/Oxi cleaning solution.

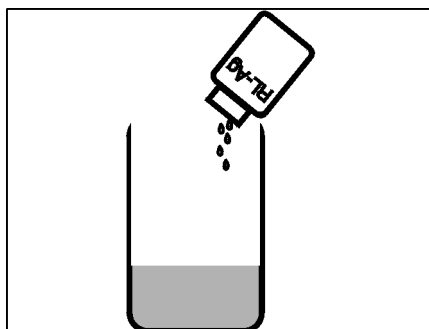

**Caution**

The reference electrode must not come into contact with the cleaning solution under any circumstances. This could destroy the reference electrode and cause the sensor to become defective.

- 3 Clamp the sensor in a stand.  
Submerge the electrode unit in the RL-AG/Oxi cleaning solution to just above the silver counter electrode.



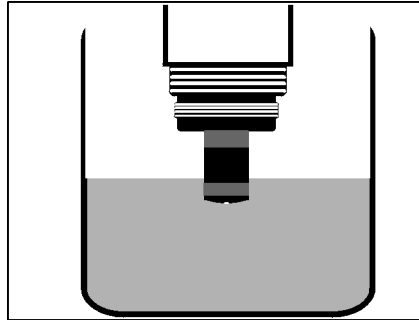

- 4 Leave the cleaning solution to work for 1 hour.
- 5 Rinse the sensor head and electrode unit several times with deionized water.

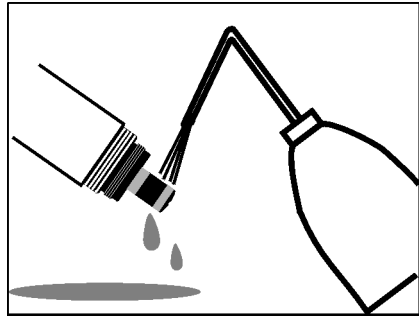

- 6 Water the sensor head and electrode unit in deionized water for at least an hour.

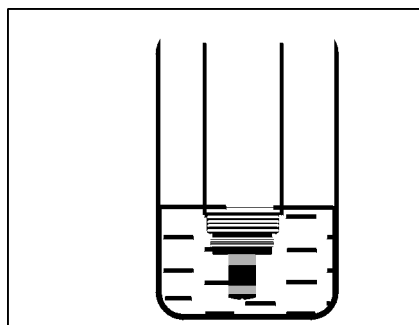

- 7 Carefully shake off the drops of water.

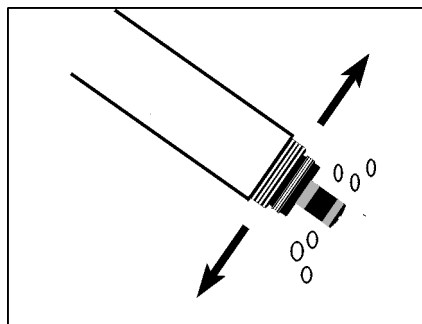

8	Fill a new WP 600 membrane cap and screw it on (see section 5.3 CHANGING THE ELECTROLYTE AND MEMBRANE CAP).
9	Connect the sensor to the measuring transmitter again.
10	After approx. 60 minutes polarization time, the sensor is ready for operation.
11	Recalibrate the sensor.

### 5.5 Checking the sensor for freedom from zero-current

The sensor is zero-current free. Therefore, calibration of the sensor in oxygen-free solution is not provided.

However, it is possible to check the freedom from zero-current according to DIN EN 25814/ISO 5814. This is advisable if there is any suspicion of a malfunction.

#### Test solution

1 g/l aqueous sodium sulfite solution, Na<sub>2</sub>SO<sub>3</sub>  
(addition of 1 mg/l of a cobalt(II) salt accelerates the removal of oxygen from the solution)



The sensor should be in operation for at least 1 hour before the inspection.

#### Test procedure



1	Clean the sensor (see section 5.2 CLEANING THE SENSOR SHAFT AND MEMBRANE).
2	On the measuring transmitter, select <i>Saturation</i> (unit %) and switch to the measured value display.
3	Submerge the sensor in the test solution.
4	Leave the sensor in the test solution for an hour.

5	Read the measured value.
---	--------------------------

**Test criterion**

The sensor is OK if < 2 % oxygen saturation is displayed as the measured value.

If the measured value is > 2 %:

- Clean the gold working electrode (see section 5.4.1 CLEANING THE GOLD WORKING ELECTRODE) and change the electrolyte and membrane cap (see section 5.3 CHANGING THE ELECTROLYTE AND MEMBRANE CAP).
- If necessary, also clean the silver counter electrode (see section 5.4.2 CLEANING THE SILVER COUNTER ELECTRODE).

**5.6 Storage**

Store the clean and dry sensor with its protective cap in place. Observe the allowed temperature range (see chapter 7 TECHNICAL DATA). The sensor may be stored in any position.

**5.7 Disposal**

We recommend to dispose of the sensor without the membrane cap as electronic refuse.

**Caution**

**The ELY/A electrolyte solution irritates eyes, skin and mucus membranes. If it comes into contact with the eyes, rinse thoroughly with water and consult a doctor! During working activities, always wear suitable protective gloves and protective goggles/face shield! Follow the safety datasheet.**

**Disposal of the membrane cap**

- |   |  |
|---|--|
| 1 | Before disposing of the membrane cap, unscrew it and rinse with water. |
| 2 | Dispose of the membrane cap in the household refuse.                   |

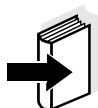
**Note**

To dispose of the chemicals, follow the corresponding safety datasheets. The safety datasheets can be obtained from WTW.

## 5.8 Maintenance equipment and replacement parts

Description	Model	Order no.
Accessory kit (2 replacement membrane caps, 50 ml electrolyte solution, 50 ml cleaning solution, polishing film)	ZBK 600	202 620
Replacement membrane caps (2 pieces)	WP 600/2	202 850
Electrolyte solution (1 bottle x 50 ml)	ELY/A	205 212
Cleaning solution for silver counter electrode (1 bottle x 50 ml)	RL-Ag/Oxi	205 200
Polishing film	SF 300	203 680
Cleaning attachment for cleaning the counter electrode	RA 600	202 510



### Note

Information on further accessories is given in the WTW catalog and in the Internet.

## 6 What to do if...

**The sensor is in the air and the display shows 0.0 mg/l or 0% O<sub>2</sub>**

Cause	Remedy
<ul style="list-style-type: none"> <li>– No electrolyte in the membrane cap</li> </ul>	<ul style="list-style-type: none"> <li>– Change the WP 600 membrane cap (see section 5.3)</li> </ul>

**The sensor cannot be calibrated**

Cause	Remedy
<ul style="list-style-type: none"> <li>– Contaminated membrane cap</li> </ul>	<ul style="list-style-type: none"> <li>– Clean the outside of the sensor (according to operating manual), wait at least 15 minutes and recalibrate.</li> <li>– In the case of contamination that cannot be removed: Exchange the membrane cap and electrolyte.</li> </ul>

**If the sensor still cannot be calibrated after changing the electrolyte and membrane cap**

Cause	Remedy
<ul style="list-style-type: none"> <li>– Contaminated electrodes or sensor toxification</li> </ul>	<ul style="list-style-type: none"> <li>– Clean the electrodes (see section 5.4)</li> </ul>

**Measured values too low**

Cause	Remedy
<ul style="list-style-type: none"> <li>– Membrane contaminated</li> <li>– Sensor has not been calibrated for a long time</li> </ul>	<ul style="list-style-type: none"> <li>– Clean the outside of the sensor, then recalibrate (see section 5.2 and section 4.2)</li> </ul>
<ul style="list-style-type: none"> <li>– Membrane does not fit snugly on the gold working electrode</li> </ul>	<ul style="list-style-type: none"> <li>– Change the membrane cap, then recalibrate (see section 5.3 and section 4.2)</li> </ul>

**Measured values too high**

Cause	Remedy
<ul style="list-style-type: none"> <li>– Sensor not yet completely polarized</li> </ul>	<ul style="list-style-type: none"> <li>– Wait for complete polarization (at least 1 hour)</li> </ul>
<ul style="list-style-type: none"> <li>– Sensor has not been calibrated for a long time</li> </ul>	<ul style="list-style-type: none"> <li>– Clean the outside of the sensor, then recalibrate (section 5.2 and section 4.2)</li> </ul>

<b>Measured value fluctuating heavily</b>	<b>Cause</b>	<b>Remedy</b>
	<ul style="list-style-type: none"><li>– Membrane head loose</li></ul>	<ul style="list-style-type: none"><li>– Screw the membrane cap tight</li></ul>
	<ul style="list-style-type: none"><li>– Membrane does not fit snugly on the gold working electrode</li></ul>	<ul style="list-style-type: none"><li>– Change the membrane cap, then recalibrate (see section 5.3 and section 4.2)</li></ul>
<b>Incorrect temperature display</b>	<b>Cause</b>	<b>Remedy</b>
	<ul style="list-style-type: none"><li>– Temperature sensor defective</li></ul>	<ul style="list-style-type: none"><li>– Return the sensor</li></ul>
<b>Mechanical damage to the sensor</b>	<b>Cause</b>	<b>Remedy</b>
		<ul style="list-style-type: none"><li>– Return the sensor</li></ul>

## 7 Technical data

### 7.1 General data

#### Measuring principle

Membrane-covered amperometric sensor with potentiostatically operated 3-electrode system

#### Dimensions

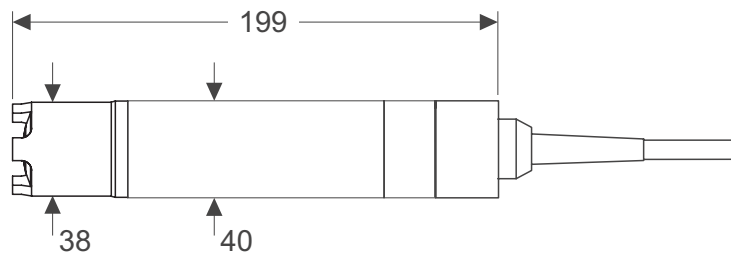

#### Weight (without sensor connection cable)

approx. 660 g

#### Membrane

Material	Fluorine plastic
Thickness	50 µm

#### Electrolyte

ELY/A

#### Temperature measurement

Via integrated NTC, - 5 °C ... + 60 °C

Accuracy	± 0.5 K
Resolution	0.1 K

#### Temperature compensation

IMT (integrated membrane temperature compensation)

#### Material

Shaft	VA steel 1.4571
Membrane cap	Polyoxymethylene (POM)
Membrane	Fluorine plastic
Sensor head	Polyoxymethylene (POM)
Insulator	Epoxy, polyetheretherketone (PEEK)
Plug head connector housing	Polyoxymethylene (POM)
Protective hood	Polyoxymethylene (POM)
Closing head	POM
Protection ring	POM

	Cable gland	V4A stainless steel 1.4571
	Cable sheath	PUR
<b>Connection cable</b>	Length	1,5 m, 7 m, 15 m (special lengths on request)
	Diameter	8.6 mm
	Smallest allowed bend radius	Permanent bend: 130 mm Short time bend: 80 mm
<b>Instrument safety</b>	Applicable norms	<ul style="list-style-type: none"> <li>– EN 61010-1</li> <li>– UL 3111-1</li> <li>– CAN/CSA C22.2 No. 1010.1</li> </ul>
<b>Electromagnetic compatibility</b>		according to EN 61326 class B and FCC class A
<b>Integrated lightning protection</b>		Yes
<b>Test certificates</b>		CE, cUL, UL



## 7.2 Measurement conditions

<b>Measuring range</b>	D. O. concentration	0.0 ... 60.0 mg/l
	D. O. saturation	0 ... 600 % ( $\approx$ 0 ... 1200 mbar pO <sub>2</sub> )
<b>Polarization time</b>	In the case of re-commissioning or change of electrolyte:	At least 60 minutes
	In the case of short polarization interruptions (depending on the duration of the interruption):	15 to 60 minutes
<b>Temperature range</b>	Measuring medium	0 °C ... + 50 °C
	Storage/transport	- 5 °C ... + 50 °C
<b>Pressure resistance</b>	Sensor including connection cable:	
	Max. allowed overpressure	10 <sup>6</sup> Pa (10 bar)
The sensor meets all requirements according to article 3(3) of 97/23/EG ("pressure equipment directive").		
<b>Type of protection</b>	Sensor including connection cable	IP 68, 10 bar
	Connector plug	IP 65
<b>Depth of immersion</b>	min. 10 cm; max. 100 m depth	
<b>Operating position</b>	Any, if the minimum approach flow is guaranteed	
<b>Approach flow</b>	$\geq$ 5 cm/s (at 1 % measurement accuracy)	

### 7.3 Characteristic data on delivery

<b>Zero signal</b>	< 0.2 % of the saturation value
<b>Response time at 25 °C</b>	$t_{90}$   (90 % of the final value display) after: < 180 s
<b>Own consumption</b>	0.0059 $\mu\text{g h}^{-1}$ ( $\text{mg/l}$ ) <sup>-1</sup> at 20 °C
<b>Drift</b>	< 1 % per month during permanent polarization
<b>Working life</b>	approx. 5 years per electrolyte filling (theoretical electrolyte reserve for operation under air saturation)

### 7.4 Electrical data

<b>Power supply</b>	via WTW measuring transmitter.
<b>Connection technique</b>	Connection cable permanently mounted on the sensor. Connection to the measuring transmitter via 7-pole screw plug.



#### Caution

All voltages must be protective low voltages or safety extra low voltages without hazard of contact according to E 61010-1 or UL 3111-1. All currents to the probe must not exceed 8 A even in case of a short-circuit.

#### Pin assignment

Pin	Assignment	Voltage	Max. current
1	Ub+	+ 6.5 V ... + 8.5 V	1 mA
2	0 V	---	---
3	NTC	< 3.5 V	0.15 mA
4	NTC	< 3.5 V	0.15 mA
5	Ub-	- 6.5 V ... - 8.5 V	1 mA
6	Reg/Leck (output signal)	- 8.5 V ... + 8.5 V	---
7	pO <sub>2</sub> (output signal)	0 V ... + 8.5 V	---

Plug from the front:

